

# FURNISHING

## Workbook 4



**Toormina High School**

Ph.02-66533077 Fax.02-66582310

**D. Schlyder**

# FURNISHING - Workbook 4

D.Schlyder

Copyright © 2000 D.A.Schlyder

Except for any fair dealing for educational purposes, research or review as permitted under the Copyright Act, no part of this publication may be reproduced by any process without the written permission of the author and publisher. The publisher is a member of Copyright Agency Limited (CAL) who, according to agreements with education authorities and other bodies, collects and distributes fees for educational copying on behalf of copyright owners. All copying for educational purposes must be carried out within the terms of the appropriate agreement. Copyright Agency Limited is empowered to enter into litigation with individuals and institutions who do not abide by these agreements or the conditions of the Copyright Act.

ISBN 1 876135 14 X

## Contents

### BASIC STATIC MACHINES & EQUIPMENT

General Safety And Maintenance.....	1
Electrical Switches.....	1
Static Machines.....	2
Spray Equipment.....	14

### OCCUPATIONAL HEALTH & SAFETY- 2

Workplace Hazards.....	17
Reporting Workplace Accidents.....	18
Handling Hazardous Material.....	20
Protective Handling Strategies.....	20
Dangerous Goods Labelling.....	21

### SURFACE PREPARATION

Defects In Timber Surfaces.....	22
Stoppings.....	23
Abrasive Paper.....	24

### PLAN READING & DOCUMENTATION

Symbols Abbreviations And Specifications.....	25
Identify And Interpret Plans.....	27

Published in Australia by  
PCS Publications  
Toowoomba 4350

Printed in Australia by  
Scanlan Printing  
Toowoomba 4350



p.c.s. publications





\$6-25

# BASIC STATIC MACHINES & EQUIPMENT

## General Safety and Maintenance

1. List five general safety precautions that apply to all machines.

- a. \_\_\_\_\_
- \_\_\_\_\_
- b. \_\_\_\_\_
- \_\_\_\_\_
- c. \_\_\_\_\_
- \_\_\_\_\_
- d. \_\_\_\_\_
- \_\_\_\_\_
- e. \_\_\_\_\_
- \_\_\_\_\_

2. List three general daily maintenance procedures that could apply to most machines.

- a. \_\_\_\_\_
- b. \_\_\_\_\_
- c. \_\_\_\_\_

## Electrical Switches

1. Typical machine switches are illustrated below. Name the switches indicated and state their colours.

Switch: \_\_\_\_\_  
 Colour: \_\_\_\_\_

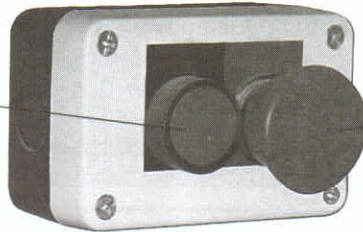

Switch: \_\_\_\_\_  
 Colour: \_\_\_\_\_

2. Briefly describe an alternative to the switch shown on the left in the photograph above.

\_\_\_\_\_  
 \_\_\_\_\_

P.C.S. Publications

19-9-01 (8082) I.A.

3. As well as the switches referred to in questions 1 and 2, all machines must have an isolating switch. Briefly state the purpose of an isolating switch.

---

---

### Static Machines

1. a. Name the machine illustrated below and state its function. Also name the parts of the machine as indicated.

Name: \_\_\_\_\_ Function: \_\_\_\_\_

---

---

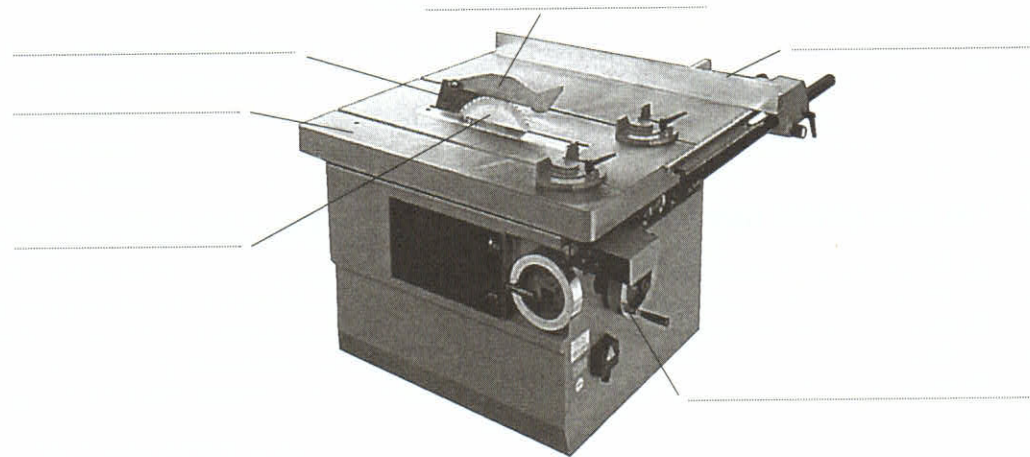

- b. How should the crown guard be adjusted when the machine is in use?

---

- c. Which way should the teeth be facing when the blade is installed?

---

- d. Why should the blade be set as high as possible when ripping?

---

- e. Why should the operator not stand directly in line with the material being cut?

---

- f. Briefly describe how bowed material should be placed when being cut.

---

**g.** List four safety precautions that should be observed to protect the hands while operating the saw.

- a. \_\_\_\_\_
- b. \_\_\_\_\_
- c. \_\_\_\_\_
- d. \_\_\_\_\_

**2. a.** Name the machine illustrated below and state its function. Also name the parts of the machine as indicated.

Name: \_\_\_\_\_ Function: \_\_\_\_\_

\_\_\_\_\_  
\_\_\_\_\_

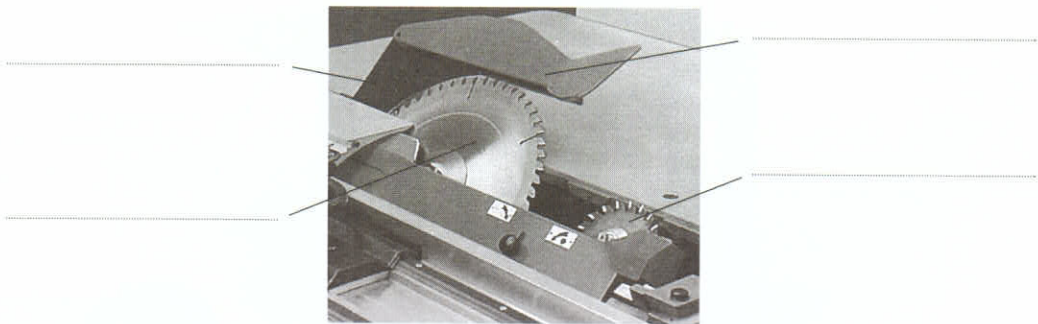
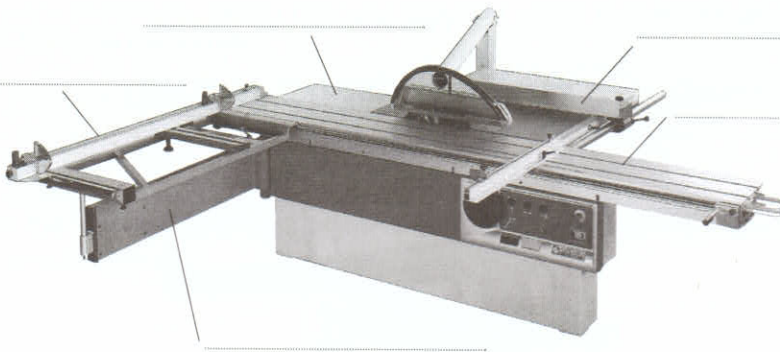

**b.** Name the type of saw blade used in the machine illustrated above.

\_\_\_\_\_

**c.** How is rise and fall of the saw blade effected on fully manual machines?

\_\_\_\_\_

d. List two operating safety precautions that relate to large sheets of material.

a. \_\_\_\_\_

b. \_\_\_\_\_

e. Briefly describe the operator's position and the reason for adopting that position.

\_\_\_\_\_

f. It is quite safe to use the ripping fence as a stop to dock narrow material.

a. True

b. False

3. a. Name the machine illustrated below and state its function. Also name the parts of the machine as indicated.

Name: \_\_\_\_\_ Function: \_\_\_\_\_

\_\_\_\_\_

\_\_\_\_\_

\_\_\_\_\_

\_\_\_\_\_

\_\_\_\_\_

\_\_\_\_\_

\_\_\_\_\_

\_\_\_\_\_

\_\_\_\_\_

\_\_\_\_\_

\_\_\_\_\_

\_\_\_\_\_

\_\_\_\_\_

\_\_\_\_\_

\_\_\_\_\_

\_\_\_\_\_

\_\_\_\_\_

\_\_\_\_\_

\_\_\_\_\_

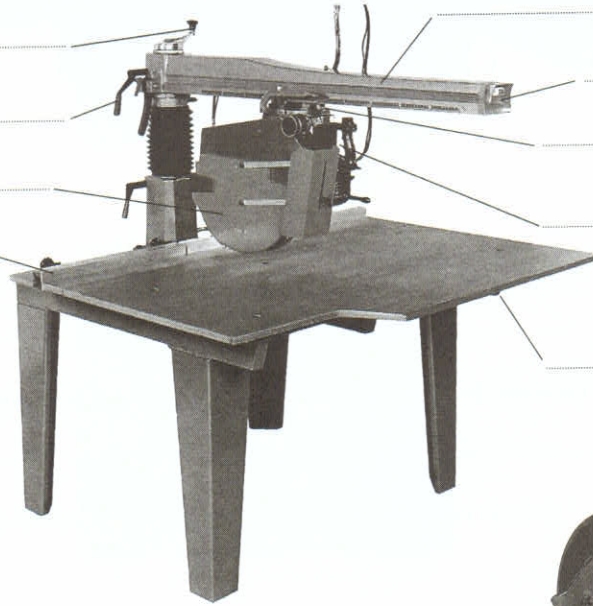

switch

switch

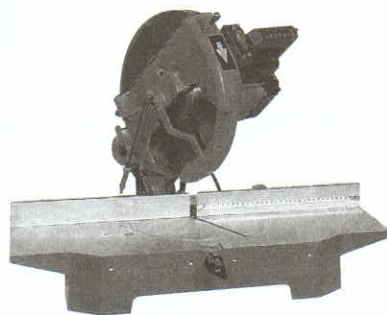

b. Name the machine illustrated on the right.



**c.** Briefly describe how the teeth should be positioned when the blade is being fitted to either of the saws illustrated on the previous page.

---

---

**d.** Which of the following operating safety precautions does not usually apply to the saws illustrated on the previous page?

- a. The saw should be operated with the hand that does not require the operator's body to be in line with the blade.
- b. Material should never be left on the table away from the fence and in line with the saw blade.
- c. Twisted material should be cut into short lengths and planed on one side before ripping.
- d. The saw should always be returned to a non-cutting position after each cut is made.

**e.** The radial arm slide mechanism should be checked for play as part of regular maintenance procedure. Briefly describe remedial action that should be taken if there is play in the slide mechanism.

---

---

**4. a.** Name the machine illustrated below and state its function. Also name the parts of the machine as indicated.

Name: \_\_\_\_\_

Function: \_\_\_\_\_

\_\_\_\_\_

\_\_\_\_\_

\_\_\_\_\_

\_\_\_\_\_

\_\_\_\_\_

\_\_\_\_\_

\_\_\_\_\_

\_\_\_\_\_

\_\_\_\_\_

\_\_\_\_\_

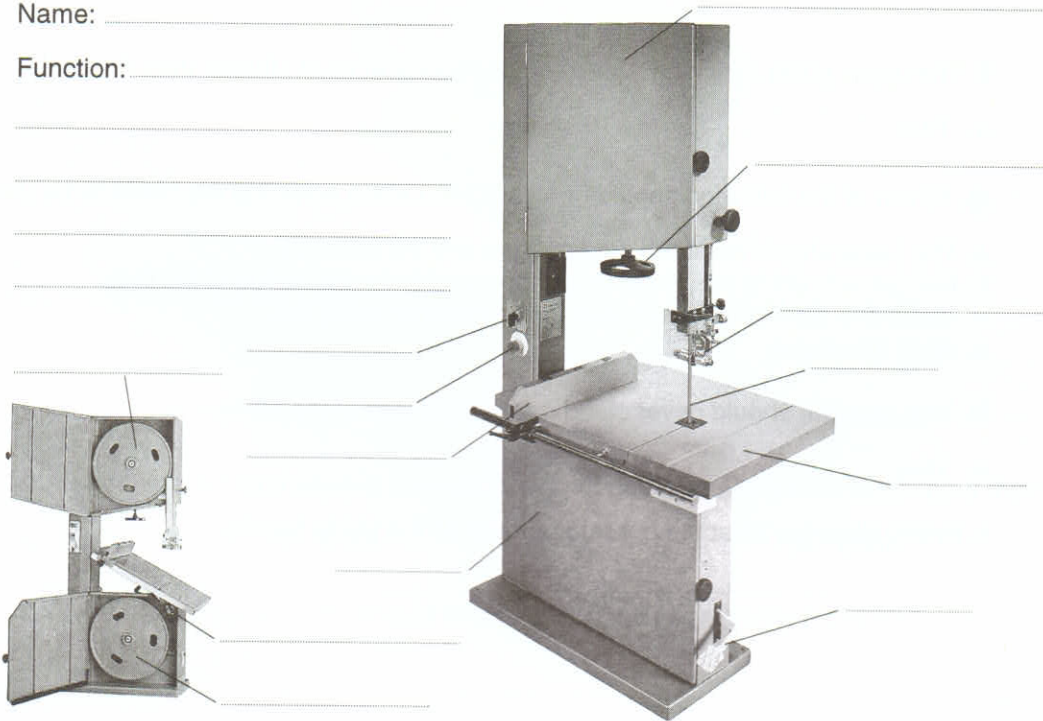

**b.** Tracking is adjusted by turning a handwheel at the back of the machine or at the front of the top wheel. Briefly explain how the tracking adjustment works.

---

---

---

**c.** Briefly describe how the teeth should be positioned when the blade is being installed.

---

---

---

**d.** Which of the following is the usual distance that guides should be set from the blade?

- a. 1.00mm            b. 0.75mm            c. 0.50mm            d. 0.25mm

**e.** Briefly describe the purpose and correct adjustment of thrust wheels.

---

---

---

---

**f.** The upper guide assembly should be positioned at least 100mm from the work.

- a. True                                    b. False

**g.** Which of the following should be considered when selecting the blade to be used?

- a. The blade should be sharp, undamaged and set correctly.  
b. For curved cutting the blade should be suitable for the radius of the cuts.  
c. The blade type should be suited to the material being cut.  
d. All of the above.

**h.** The operator should never stand on the right side of the blade.

- a. True                                    b. False

**i.** Briefly describe what the operator should do if a blade breaks.

---

---

---



**j.** List five checks that could be made as part of regular maintenance procedure.

- a. \_\_\_\_\_
- b. \_\_\_\_\_
- c. \_\_\_\_\_
- d. \_\_\_\_\_
- e. \_\_\_\_\_

**5. a.** Name the machine illustrated below and state its function. Also name the parts of the machine as indicated.

Name: \_\_\_\_\_ Function: \_\_\_\_\_

\_\_\_\_\_

\_\_\_\_\_

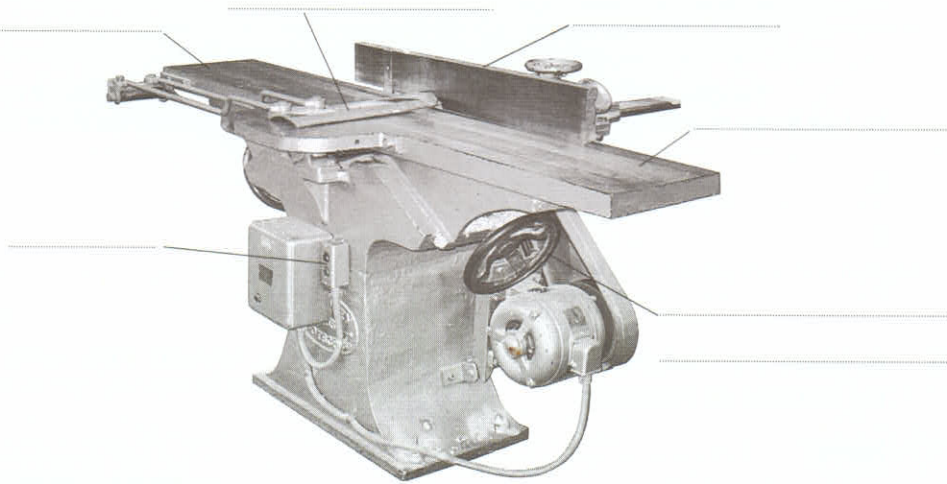

**b.** Briefly describe the position of the outfeed table in relation to the cutters.

\_\_\_\_\_

\_\_\_\_\_

**c.** For general surface planing operations the cut depth should be set to no more than:

- a. 6mm
- b. 4mm
- c. 2mm
- d. 1mm

**d.** In relation to safety, why should timber always be planed with the grain?

\_\_\_\_\_

e. Briefly describe the operating procedure which ensures that hands in contact with the timber never pass over the cutters.

---

---

---

---

---

---

f. A guard need not be fitted behind the fence if cutters are exposed.

- a. True                      b. False

g. Before planing, timber should always be checked for straightness. Briefly describe the treatment of bowed or twisted surfaces in relation to selecting the face and edge.

---

---

---

---

h. List three checks that should be made as part of regular maintenance procedure.

- a. \_\_\_\_\_  
b. \_\_\_\_\_  
c. \_\_\_\_\_

6. a. Name the machine illustrated below and state its function. Also name the parts of the machine as indicated.

Name: \_\_\_\_\_

Function: \_\_\_\_\_

---

---

---

---

---

---

---

---

---

---

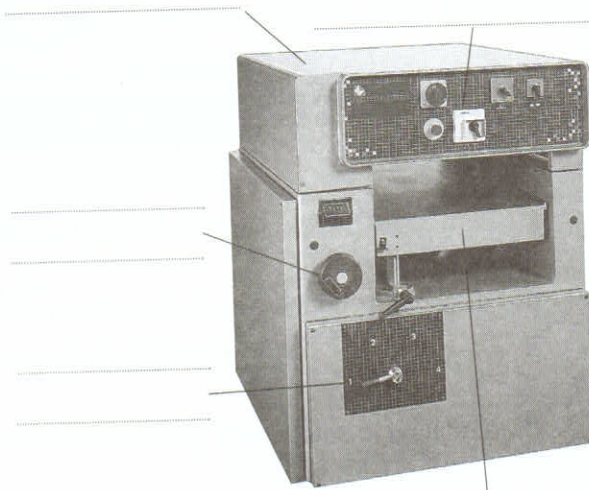

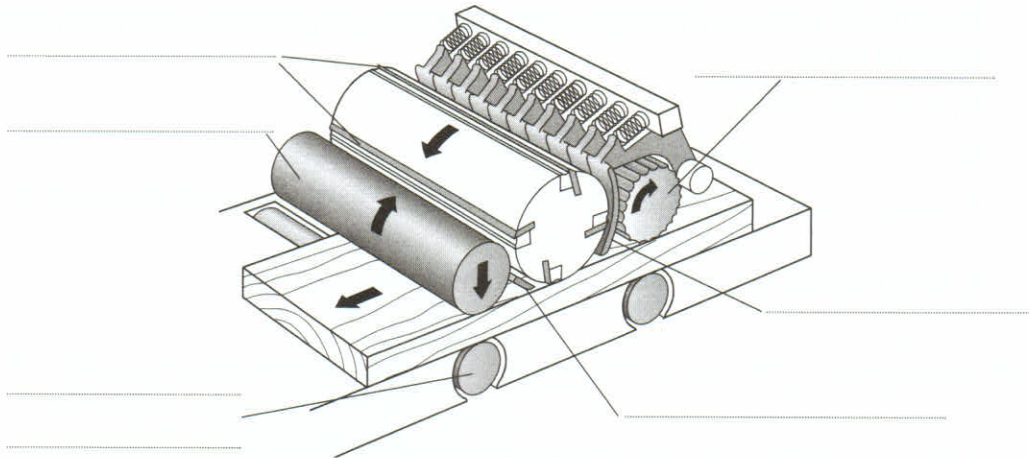

**b.** Briefly describe a procedure which avoids inaccuracies in rise and fall adjustments that may be due to wear in the rise and fall mechanism.

.....

.....

**c.** When would a slow feed speed be used in thickening operations?

.....

.....

**d.** Feed speed can generally be varied within the range of 5 to 20 metres per minute.

- a. True                                      b. False

**e.** What is the function of the pressure bars?

.....

.....

**f.** Which of the following rollers is/are power driven and fluted on most machines?

- a. Anti-friction rollers
- b. Infeed roller
- c. Outfeed roller
- d. Both infeed and outfeed rollers

**g.** List three operating safety precautions that should be observed to prevent or avoid kickback.

a. ....

b. ....

c. ....



**h.** List three additional operating safety precautions that should be observed to prevent personal injury.

- a. \_\_\_\_\_
- b. \_\_\_\_\_
- c. \_\_\_\_\_

**i.** Briefly explain why the width of timber should be planed first.

\_\_\_\_\_  
\_\_\_\_\_

**j.** What should the table and rollers be checked for as part of daily maintenance?

\_\_\_\_\_

**7. a.** Name the machine illustrated below and state its function. Also name the parts of the machine as indicated.

Name: \_\_\_\_\_ Function: \_\_\_\_\_

\_\_\_\_\_  
\_\_\_\_\_

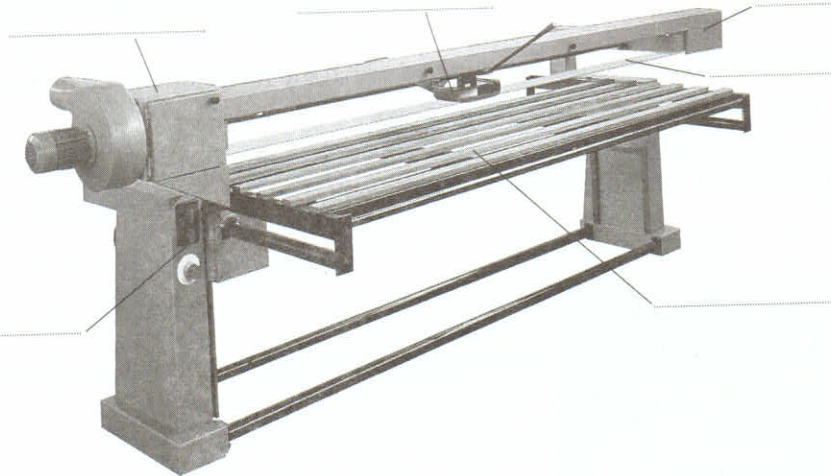

**b.** The drive pulley is on the right hand end of the abrasive belt and the idler pulley is on the left.

- a. True
- b. False

**c.** On modern machines the rise and fall is generally activated by an electrical switch.

- a. True
- b. False

d. Briefly explain the purpose of tracking adjustment.

---

---

e. Briefly explain the purpose of the belt tensioner.

---

---

f. In the adjacent rectangle, draw an enlarged edge view of an abrasive belt showing the join. Also draw an arrow to indicate the direction of belt rotation.



g. List three pre-operational safety checks that relate to the dust produced by sanding operations.

- a. \_\_\_\_\_
- b. \_\_\_\_\_
- c. \_\_\_\_\_

h. List two operating safety precautions that should be observed to avoid personal injury when the machine is running.

- a. \_\_\_\_\_
- b. \_\_\_\_\_

8. a. Name the machine illustrated below and state its function. Also name the parts of the machine as indicated.

Name: \_\_\_\_\_

Function: \_\_\_\_\_

---

---

---

---

---

---

---

---

---

---

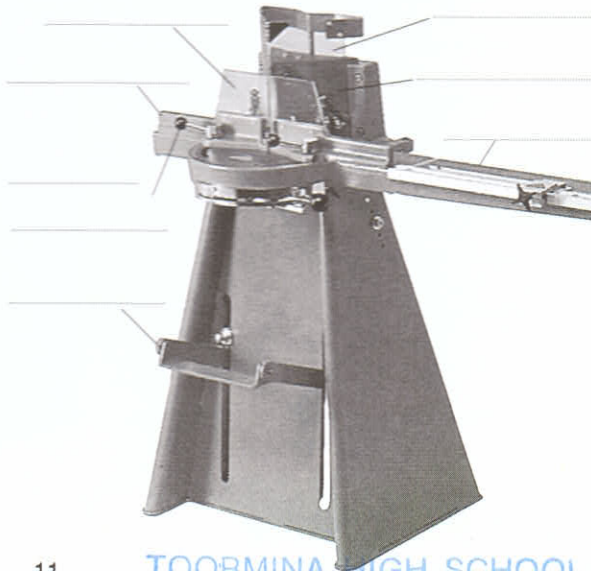

**b.** Name the parts of the machine that are used to prevent the under side of the rebate in framing material from breaking away due to the downward pressure of the cutting action.

.....

**c.** Briefly describe the operating system on a pneumatic machine that ensures the operator's hands are kept away from the knives during the cutting action.

.....  
.....  
.....

**d.** Briefly describe a safety precaution that applies only to pneumatic machines when preparing for set-up or maintenance.

.....

**e.** Briefly describe an operating safety precaution that should be employed when using the foot pedal on a foot operated machine.

.....  
.....  
.....

**9. a.** Name the machine illustrated below and state its function. Also name the parts of the machine as indicated.

Name: .....

Function: .....

.....  
.....  
.....  
.....  
.....  
.....  
.....  
.....

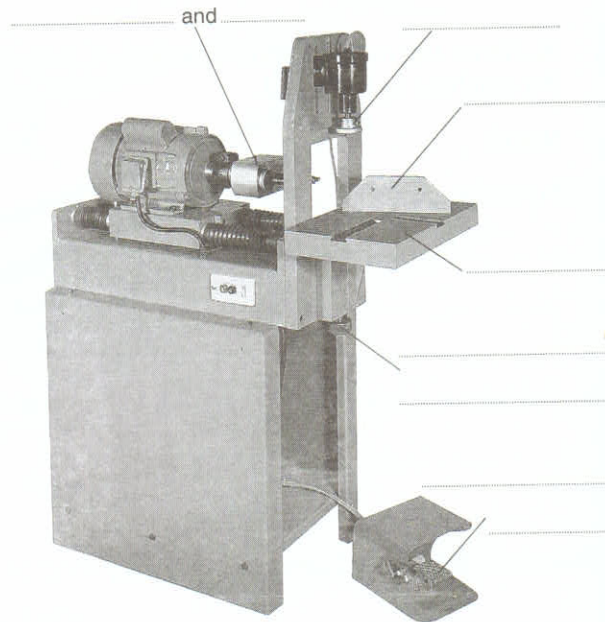



**b.** Briefly describe how the cycle control pedal operates the pneumatic clamping and travel cycle.

---

---

---

---

**c.** Describe a pre-operational safety check that relates to the pneumatic operation of the machine.

---

---

**d.** List four operational safety precautions that should be followed for the protection of the operator's hands and fingers.

- a. \_\_\_\_\_
- b. \_\_\_\_\_
- c. \_\_\_\_\_
- d. \_\_\_\_\_

**10. a.** Name the machine illustrated on the right and state its function. Also name the parts of the machine as indicated.

Name: \_\_\_\_\_

Function: \_\_\_\_\_

---

---

---

---

---

---

---

---

---

---

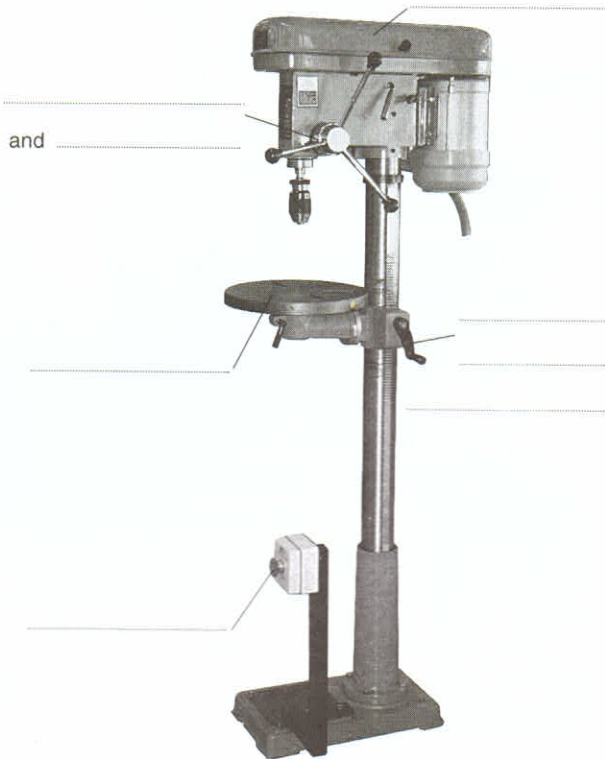

b. Briefly describe how drill speeds are varied.

.....  
.....  
.....

c. Describe a pre-operational safety procedure that relates to drill speed.

.....  
.....

d. List three operating safety precautions that should be observed if the machine is not fitted with a keyless chuck.

- a. ....
- b. ....
- c. ....

e. List three operating safety precautions that should be observed to protect the operator's hands while the machine is running.

- a. ....
- b. ....
- c. ....

### Spray Equipment

1. a. Identify the item of spray equipment shown on the right and name its parts as indicated.

b. What is the purpose of the item of spray equipment shown on the right?

.....  
.....  
.....  
.....  
.....  
.....

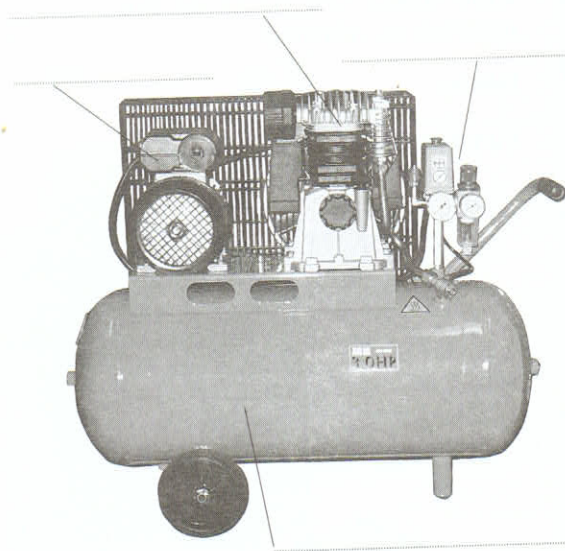

Name: .....

**C.** List three checks or procedures that should be part of daily maintenance of the item of spray equipment shown on the previous page.

- a. \_\_\_\_\_
- b. \_\_\_\_\_
- c. \_\_\_\_\_

**2.** List two checks or procedures that should be part of daily maintenance of hoses.

- a. \_\_\_\_\_
- b. \_\_\_\_\_

**3. a.** List four elements that external mix spray guns require to operate.

- a. \_\_\_\_\_
- b. \_\_\_\_\_
- c. \_\_\_\_\_
- d. \_\_\_\_\_

**b.** Name the parts of the general purpose spray gun shown on the right.

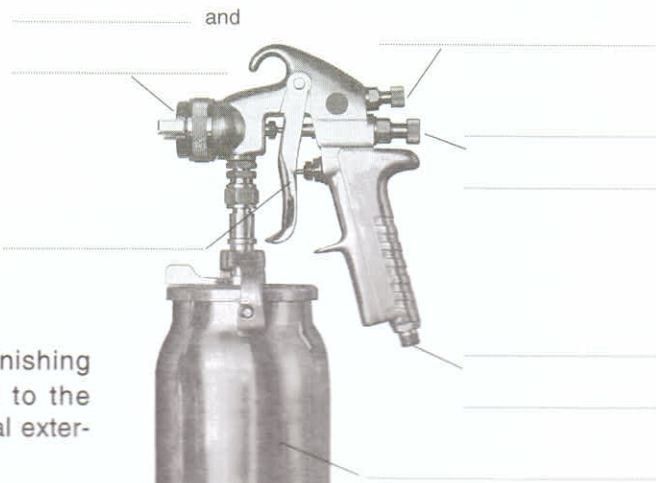

**c.** The spray gun on the right operates on a gravity feed system.

- a. True
- b. False

**d.** What proportion of the finishing material is actually applied to the work surface by a conventional external mix spray gun?

- a. 20% to 30%
- b. 40% to 50%
- c. 60% to 70%
- d. 80% to 90%

**4. a.** A typical pressure pot which contains the liquid finishing material is illustrated on the right. Briefly explain how the pressure pot works.

\_\_\_\_\_

\_\_\_\_\_

\_\_\_\_\_





**b.** Name the air assisted feed system illustrated on the right and briefly describe its operation.

Name: \_\_\_\_\_

Operation: \_\_\_\_\_

\_\_\_\_\_  
\_\_\_\_\_  
\_\_\_\_\_



**c.** Daily maintenance of feed systems should include checking rubber seals and operation of safety valves.

- a. True
- b. False

**5. a.** Name the parts of the open front spray booth shown on the right.

**b.** List three basic functions of a spray booth.

a. \_\_\_\_\_

\_\_\_\_\_

b. \_\_\_\_\_

\_\_\_\_\_

c. \_\_\_\_\_

\_\_\_\_\_

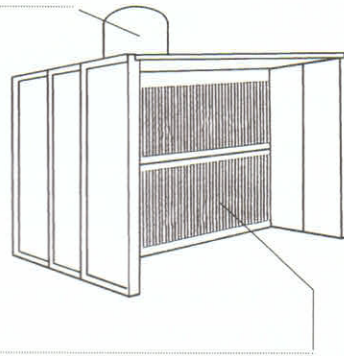

**c.** List three daily maintenance procedures for a spray booth.

a. \_\_\_\_\_

b. \_\_\_\_\_

c. \_\_\_\_\_

**6. a.** Briefly state two safety precautions that relate to compressed air or air pressure.

a. \_\_\_\_\_

b. \_\_\_\_\_

**b.** Briefly state two safety precautions that relate to sources of ignition.

a. \_\_\_\_\_

b. \_\_\_\_\_

# OCCUPATIONAL HEALTH & SAFETY - 2

## Workplace Hazards

1. Insert the terms whose explanations or descriptions are given below.
  - a. \_\_\_\_\_: Any event which results in human injury or damage to property, or any event which may have caused human injury or damage to property.
  - b. \_\_\_\_\_: Any situation in the workplace which has the potential to cause or contribute to the occurrence of an accident.
  - c. \_\_\_\_\_: The degree of probability that an accident could occur in the workplace because a certain hazard exists.
2. Complete the following sentences:
  - a. \_\_\_\_\_ hazards are often slow to take effect and may exist undetected for a long period of time.
  - b. \_\_\_\_\_ hazards are immediate in their effects and are generally easy to identify and relatively simple to control.
3. Which of the following could be described as a possible chronic hazard.
  - a. A machine that does not have proper guards installed.
  - b. Rotten or broken boards in a wooden floor.
  - c. Repeating the same physical action constantly over a long period of time.
  - d. Dangerous chemicals that are not stored correctly.
4. List the four hazard groups that may be found in the workplace.
  - a. \_\_\_\_\_
  - b. \_\_\_\_\_
  - c. \_\_\_\_\_
  - d. \_\_\_\_\_

5. Conducting a safety inspection of the machine shop you found that the emergency stop button on a vertical drill had been installed too low to be activated effectively by the operator's knee.

Complete the hazard report and make recommendations for remedial action. Refer to the checklist on page 199 of the textbook for the appropriate hazard code.

HAZARD REPORT	
Date: _____	
Inspected by: _____	
Location: _____	
Hazard Code: _____	Sketch or photo of hazard
<b>Description Of Hazard</b>	
<b>Recommendation / Action</b>	

6. Which of the following would usually be the most effective method in the hierarchy of hazard control?
- a. Engineering controls                      b. Substitution                      c. Elimination  
d. Personal protective equipment        e. Administrative controls
7. Which of the hazard control measures listed in question 6 would be used when all others are inadequate?
- 

### Reporting Workplace Accidents

1. Which of the following is not a category of injury or disease related information which can be used to identify and allocate code numbers to workplace injuries or diseases?
- a. Nature of injury                              b. Nature of disease  
c. Severity of injury or disease              d. Bodily location of injury or disease

2. Your workmate Woodie (William) Butcher was injured three quarters of an hour after starting work on the first shift (8am to 4pm) March 15, 200X. He is about the same age as you, born June 4, 19XX.

Woodie is employed as an apprentice cabinetmaker and has received thorough induction training as well as training in the tasks he performs each day, such as assembling and sanding items of furniture.

The injury occurred when a heavy sash cramp fell from a bench in the assembly area and crushed the big toe on his right foot. Fortunately there was no fracture and the skin wasn't broken.

Complete the accident report form (allocated reference number A0012) on the following page. Refer to pages 200 and 201 of the textbook for code numbers required in questions 12, 13 and the last part of 14 in the accident report form.

3. Worker's compensation is usually payable for work related injuries and diseases.
- a. True    b. False
4. Worker's compensation may not be payable for an injury where:
- a. The worker was engaging in serious and deliberate misconduct.  
b. The worker was affected by alcohol.  
c. The worker was affected by drugs.  
d. Any of the above.
5. If an injured worker was not following safe work practices, or was acting without instructions or supervision, worker's compensation can never be paid.
- a. True    b. False



# Workplace Injury and Disease Recording Form

## Personal details of the injured worker

1 Surname   
 Given names

2 Sex (M or F)

3 Date of Birth  Day  Month  Year

## Basis of employment

4 Starting time: 1  0600-1159 hours  
 2  1200-1559 hours  
 3  1600-0559 hours

5 Shift arrangement 1   
 2

6 Number of hours 1  8 hours or less  
 2  more than 8 hours (excluding overtime)

## Job details

7 Description of occupation or job title

8 Main tasks performed

9 Training provided 1  Induction training  
 2  Task specific training  
 3  Both of the above  
 4  Neither of the above

## Details of the injury or disease

10 Date injury occurred or disease reported  Day  Month  Year

11 Time injury occurred (24 hour clock format)

12 Nature of injury or disease   
  
 Code

13 Bodily location of injury or disease   
  
  
 Code

Reference number

14 Description of occurrence of injury or disease:

- In which part of the workplace did the injury or disease exposure occur?  
 (e.g. machine shop, freezer room, No 2 mine)

- What was the worker doing at the time?  
 (e.g. driving a fork lift truck, lifting bags of cement, typing)

- What happened unexpectedly?  
 Include the name of any particular chemical product, process or equipment involved.  
 (e.g. brakes failed on fork lift truck, slipped on wet floor, scaffolding collapsed, arm started hurting while typing on a word processor)

- How exactly was the injury or disease sustained?  
 Include the name of any chemical, product, process or equipment involved.  
 (e.g. hit head on cabin fork lift truck, lacerated knee when landing on ground, arm hurt after long period of typing)

(See pages 25-28 of the Standard)

{ Mechanism of injury

{ Breakdown agency

{ Agency of injury

Form continued on back of this page

## Handling Hazardous Material

1. List three forms in which workplace hazardous substances can be found.  
a. \_\_\_\_\_ b. \_\_\_\_\_ c. \_\_\_\_\_
2. List three physical hazards that can be presented by workplace chemicals.  
a. \_\_\_\_\_ b. \_\_\_\_\_ c. \_\_\_\_\_
3. List six health effects that can be caused by workplace chemicals.  
a. \_\_\_\_\_ b. \_\_\_\_\_ c. \_\_\_\_\_  
d. \_\_\_\_\_ e. \_\_\_\_\_ f. \_\_\_\_\_
4. List three techniques for investigating health hazards of chemicals.  
a. \_\_\_\_\_ b. \_\_\_\_\_ c. \_\_\_\_\_
5. LD50's are exposure standards which can indicate the relative safety of alternative chemicals. Which of the following should indicate the safer chemical?  
a. LD50 of 50mg/kg                      b. LD50 of 200mg/kg

## Protective Handling Strategies

1. List three routes by which dangerous chemicals can enter the body.  
a. \_\_\_\_\_ b. \_\_\_\_\_ c. \_\_\_\_\_
2. Hierarchy of control principles can be applied to the handling of dangerous substances in the workplace. After identifying dangerous substances, which of the following would be at the top of the hierarchy of control.  
a. Wear protective equipment or clothing.  
b. Implement specified precautions such as ensuring adequate ventilation.  
c. Eliminate harmful substances or replace them with less harmful alternatives.  
d. Know the appropriate first aid procedure in case of accident.
3. Which of the following is not usually included in a Material Safety Data Sheet.  
a. The product name and chemical names of ingredients.  
b. Properties of the substance and health hazard information.  
c. Precautions for safe use and handling.  
d. Cost and a list of retailers who sell the product.
4. A Material Safety Data Sheet could be used to identify necessary control measures before the introduction of a new substance in the workplace.  
a. True                                      b. False

5. Briefly describe the steps in a procedure that could be used to introduce a new hazardous material into the workplace.
- \_\_\_\_\_
  - \_\_\_\_\_
  - \_\_\_\_\_
  - \_\_\_\_\_
  - \_\_\_\_\_
  - \_\_\_\_\_
  - \_\_\_\_\_
  - \_\_\_\_\_
  - \_\_\_\_\_

### Dangerous Goods Labelling

1. Dangerous goods labels must be displayed when dangerous goods are stored or transported.

a. True                                      b. False

2. What is the risk description of materials represented by the dangerous goods class diamond on the right.



\_\_\_\_\_

\_\_\_\_\_

3. What is the risk description of materials represented by the dangerous goods class diamond on the right.



\_\_\_\_\_

\_\_\_\_\_

\_\_\_\_\_

4. Give the dangerous goods descriptions for each of the class numbers below.

Class 1. \_\_\_\_\_ Class 2. \_\_\_\_\_

Class 5. \_\_\_\_\_ Class 8. \_\_\_\_\_

5. What general procedures are indicated by a three digit alpha-numeric HAZCHEM code in a composite warning sign?

\_\_\_\_\_

\_\_\_\_\_





6. Refer to the table on page 211 of the textbook and interpret the HAZCHEM code in the previous question.

- a. \_\_\_\_\_
- b. \_\_\_\_\_
- c. \_\_\_\_\_
- d. \_\_\_\_\_
- e. \_\_\_\_\_

7. A typical example of an emergency information panel is shown on the right. Where must emergency information panels be displayed?

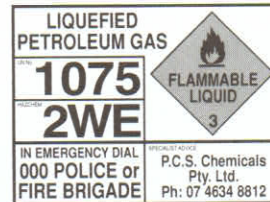

\_\_\_\_\_

\_\_\_\_\_

8. Emergency information panels usually include the name of the substance, dangerous goods class, HAZCHEM code, emergency phone numbers and another number such as 1075 as illustrated above. What is this number, what does it represent and where is it used?

\_\_\_\_\_

\_\_\_\_\_

9. Shipping labels are required to display a range of product information. Which of the following would not usually be included on a shipping label?

- a. Exposure standard and related research information.
- b. Substance name, ingredients, UN number and dangerous goods class.
- c. Risks, safety and environmental precautions, first aid and emergency procedures.
- d. Expiry date, manufacturer's details and reference to an MSDS.

## SURFACE PREPARATION

### Defects In Timber Surfaces

1. Removing a bruise involves raising the depressed wood fibres. Briefly describe two different procedures for removing a bruise and their effects on the wood fibres.

- a. \_\_\_\_\_
- \_\_\_\_\_
- b. \_\_\_\_\_
- \_\_\_\_\_
- \_\_\_\_\_

2. How can water stain around the damaged area be avoided when removing a bruise on the surface of timber?

---

---

3. Why should fine cross sanding marks be removed by sanding with the grain, particularly where the surface is to be stained and polished?

---

---

4. Dirt marks and pencil marks can usually be sanded off or may require light scraping before sanding.

- a. True    b. False

5. Which of the following may not be satisfactorily removed by lightly planing with a sharp smoothing plane or scraping with a hand scraper, then sanding?

- a. Smearred glue marks    b. Grease marks  
c. Machine marks    d. Deeper cross sanding marks

6. Briefly describe the procedure for removing the mark which is your answer to question 5.

---

---

7. Briefly describe the removal of a scratch which has torn some wood fibres and caused some indentation in the timber surface.

---

---

8. A cross shake or stress fracture can be removed by machine sanding.

- a. True    b. False

9. Briefly describe the treatment of a loose knot in the surface of timber.

---

---

10. Briefly describe the treatment of small splits in solid timber.

---

---

### Stoppings

1. List three commonly used stoppings that are available in a range of wood colours.

- a. \_\_\_\_\_ b. \_\_\_\_\_ c. \_\_\_\_\_

2. Which of the following stoppings would be most suitable for a large edge repair where accurate colour matching is not important?
- a. Epoxy putty  
b. Synthetic wax  
c. Oil putty  
d. Water putty
3. Which of the following is not a property or characteristic of synthetic wax stoppings?
- a. Easy to apply  
b. Absorbs stain easily  
c. No setting time required  
d. Suitable for small repairs
4. Briefly describe the preparation and setting action of epoxy putty.
- .....  
.....
5. Holes should never be overfilled during the stopping process.
- a. True  
b. False
6. Why should the selected colour of wood putty always be as close as possible to the natural colour of the timber?
- .....
7. Why should the selected colour of wax stoppings always be as close as possible to the finished colour of the furniture piece?
- .....
8. Which of the following stoppings cannot be sanded flush when used to fill nail holes?
- a. Water putty  
b. Wood putty  
c. Synthetic wax  
d. Epoxy putty

### Abrasive Paper

1. Abrasive paper could be described as *fine* if its grade is in the range of:
- a. 36 to 40  
b. 60 to 80  
c. 100 to 180  
d. 220 to 1200
2. Name the four abrasives or abrasive papers described below.
- a. .... : Grit fractures to form new cutting edges; not waterproof; reddish-brown colour; natural semi-precious stone; medium hardness and toughness.
- b. .... : Shiny, black, extremely hard; made from coke and sand fused together; fractures into sharp wedge-shaped slivers; bonded to waterproof sheets.
- c. .... : Grit may be crushed glass, quartz or flint; yellowish colour; not waterproof; grit loses sharpness quickly compared to other abrasive papers.
- d. .... : Made from bauxite, iron filings and coke, fused and ground; extremely tough; brown colour; suited to machine sanding; wears very well.



# PLAN READING & DOCUMENTATION

## Symbols Abbreviations And Specifications

1. Briefly explain the basic difference between plans and specifications.

---



---

2. List seven items or areas of information that could be included in a title block.

a. \_\_\_\_\_

b. \_\_\_\_\_

c. \_\_\_\_\_

d. \_\_\_\_\_

e. \_\_\_\_\_

f. \_\_\_\_\_

g. \_\_\_\_\_

3. Name the standard symbols listed in the table on the right.

4. The floor plan of a toilet facility is illustrated below.

The symbols for the water closet (toilet) and the vanity basin are non-standard and would never be used in an architect's drawing.

- a. True
- b. False

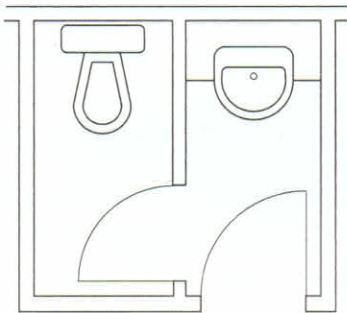

ITEM	SYMBOL

5. Some of the standard hatching and material presentation symbols are shown in the table on the right. Name the materials which are illustrated by the symbols.

6. Briefly explain why abbreviations are often used in working drawings.

.....

.....

.....

.....











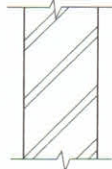

.....

.....

.....

7. Write the standard abbreviations after the terms listed below.

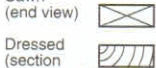
- a. Adhesive .....
- b. Built-in .....
- c. Bullnose .....
- d. Cabinet .....
- e. Cupboard .....
- f. Sliding Door .....
- g. Softwood .....
- h. Wardrobe .....

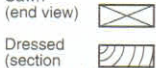
Material	Large Scale Drawings - Section
	
	
	
	
	
	
	
	
	
	   

8. The specification for a building project is usually a large document. Briefly state, in general terms, what a specification contains.

.....

.....

.....

9. Example 1 on pages 223 and 224 of the textbook is a typical standard specification for painting and clear finishing of surfaces. Extract the following information from this specification:

a. State a specific instruction in relation to spraying clear finishes.

.....

b. Unless otherwise specified or necessary, how many coats should be applied in each paint system?

.....

10. Example 2 on pages 224 and 225 of the textbook is a specification for cupboard work taken from an architect's drawing. Extract the following information from this specification:

a. State a general instruction in relation to on site dimensions and equipment sizes.

.....

.....

.....

b. State a specific instruction in relation to drawers.

.....

.....

### Identify And Interpret Plans

1. List two main classifications under which drawings could be described.

a. ....

b. ....

2. Identify the types of drawings illustrated below.



a. ....

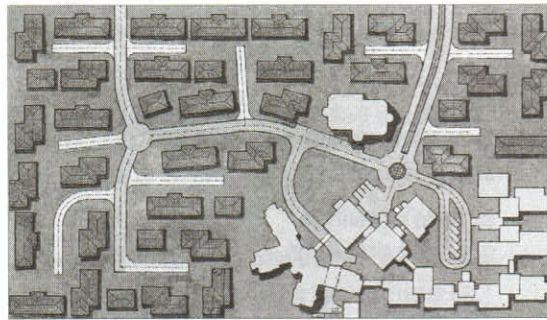

b. ....



3. Identify the type of drawing illustrated on the right.

.....

4. You have been given the job of building some of the cupboards in the house whose floor plan is shown on page 228 of the textbook. Another firm has been given the contract for the kitchen cupboards.

Refer to the floor plan and list the location and type of all the cupboards you will be building.

.....

.....

.....

.....

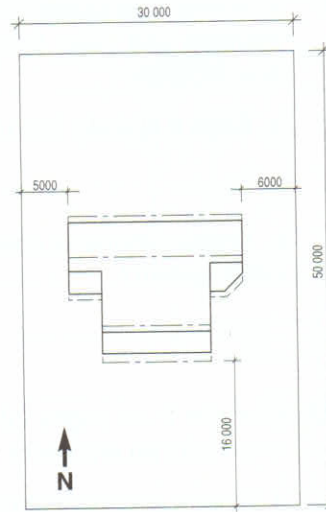

5. Refer to the drawing above and the floor plan on page 228 of the textbook and name the drawing on the right.

The name is to indicate the type of drawing and the directional aspect of the building.

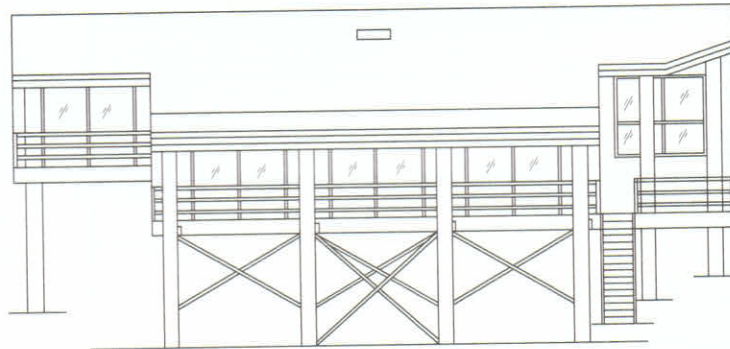

6. Briefly describe what is shown in a sectional view of a building such as the house illustrated above.

.....

.....

.....

7. Drawings which show all the details that are necessary for the manufacture of items such as furniture, cupboards and fixtures that are part of a building project, are called:

- a. Item drawings
- b. Component drawings
- c. Detail drawings
- d. Isometric drawings

8. A full size set-out rod is usually made from the drawings referred to in question 7.

- a. True
- b. False

9. Section A-A of a Cashier's Counter is shown below. Other drawings and information can be found on pages 230 to 232 of the textbook.

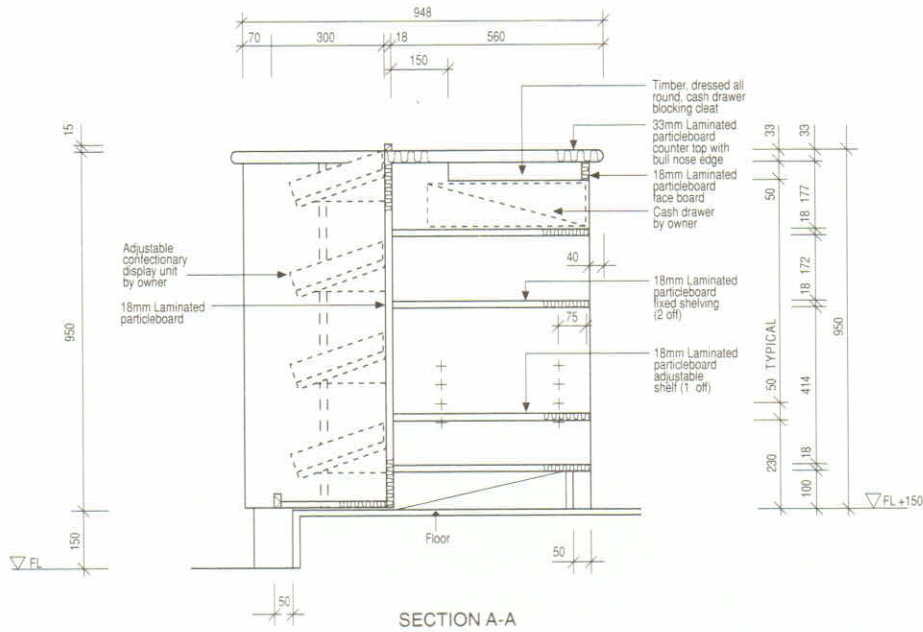

a. Describe the material from which the panels are cut.

.....

b. Describe the counter top.

.....  
 .....

c. What is the height of the counter top above floor level.

.....

d. How many adjustable shelves are there in the right hand end of the counter?

.....

10. Sketch working drawings of a current practical project or other article as directed by your instructor. (This may have been completed as part of the Drawing module.)

TOORMINA HIGH SCHOOL



R24335F.8527